

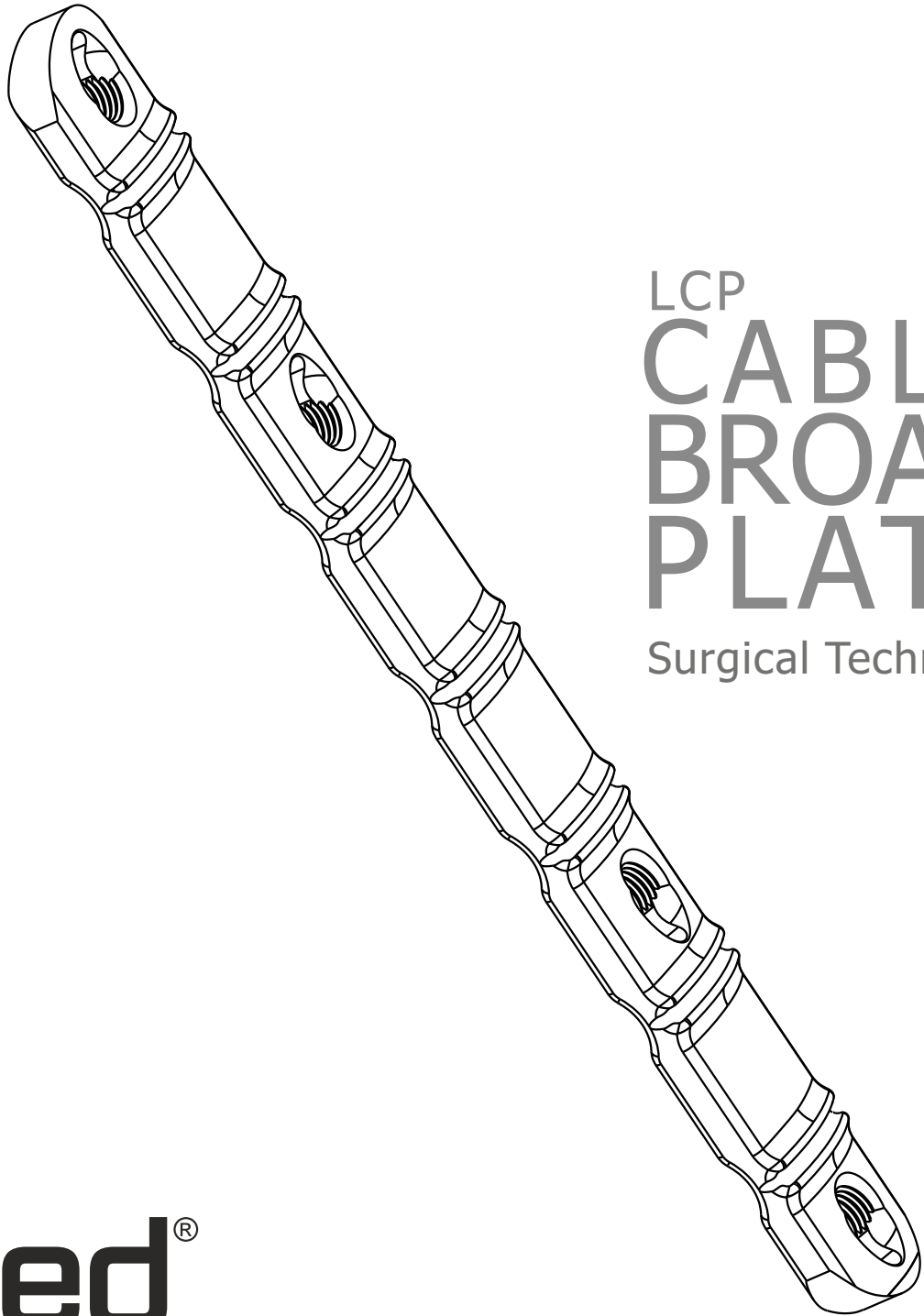

www.zimed.com.tr



LCP
**CABLE
BROAD
PLATE**
Surgical Technique

zimed[®]



www.zimed.com.tr

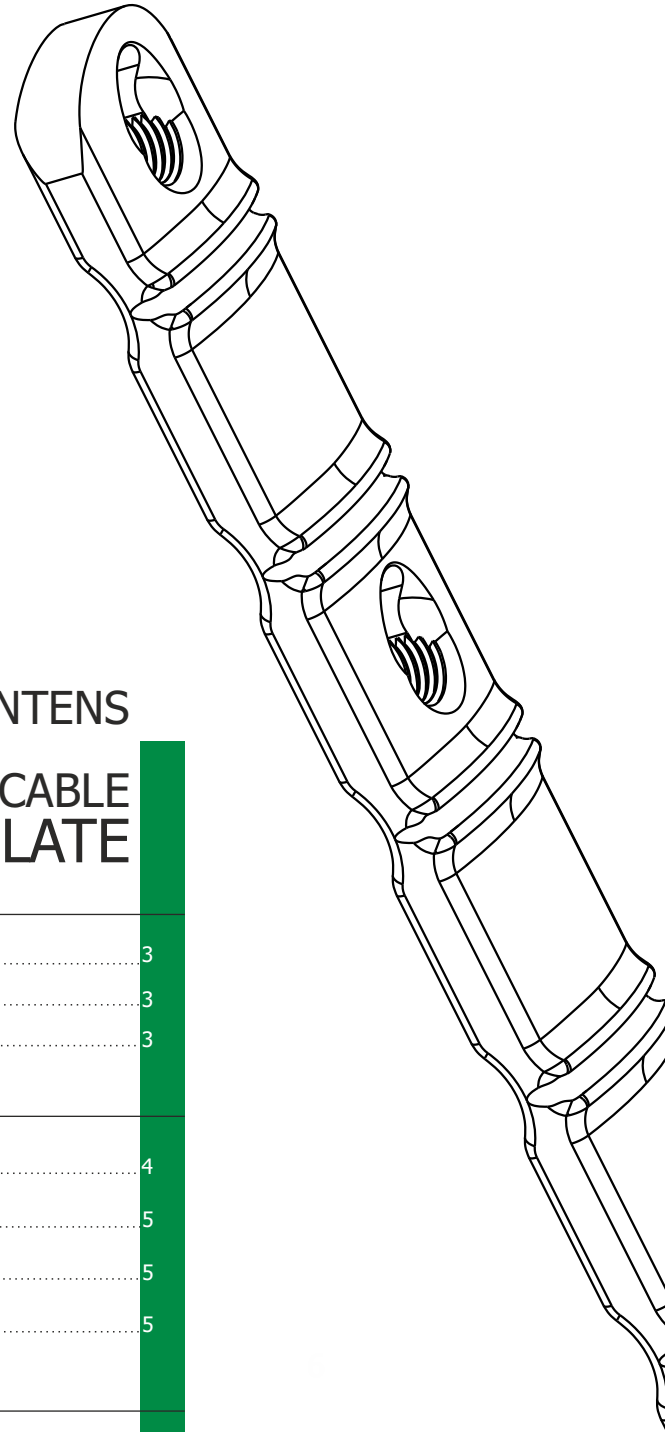

CONTENS

LCP CABLE BROAD PLATE

1. Introduction

1.1. Spesification.....	3
1.1.1. LCP Cable Broad Plate.....	3
1.1.2. Cable.....	3

2. Surgical Technique

2.1. Plate and Cable Placement.....	4
2.2. Cable Tensioning.....	5
2.3. Cable Fixing.....	5
2.4. Finishing.....	5

3. Instrument Set

3.1. Instrument Set - 1. Tray.....	6
3.2. Instrument Set - 2. Tray.....	6

4. Disinfection

4.1 Device Cleaning Conditions.....	7
4.1.1. Manual Cleaning/Disinfection.....	7
4.1.2. Combination Manual / Automated Cleaning and Disinfection.....	7
4.1.3. Combination Manual / Automated Cleaning and Disinfection.....	7

zimed[®]

ISO 9001:2015
ISO 13485:2016  1984



1.1. Specifications

1.1.1. LCP Cable Broad Plate

It is designed for strong fracture stabilization. Especially in complex fractures, osteotomy in malunion cases and pseudoarthrosis. Cable locking broad plate is used with Ø5,0 locking and Ø4,5 mm cortical screws. It is made of titanium alloy manufactured according to ASTM F 136 standard. It is offered for sale in 3 different lengths as 172, 193, 215 mm and 4,5,6, holes. The thickness is 5,4mm for all lengths and 7,8,9 cable locked broad plate rows for each.

zimed[®]

Cable LCP Broad Plate

(with Ø 5,0 locking & Ø4,5 cortical screw)

REF. NO	HOLES
1982-0004	4
1982-0005	5
1982-0006	6

Cortical screw home mechanism

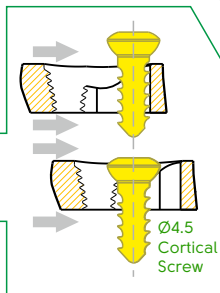

Cable line: - Ø 2.0 mm

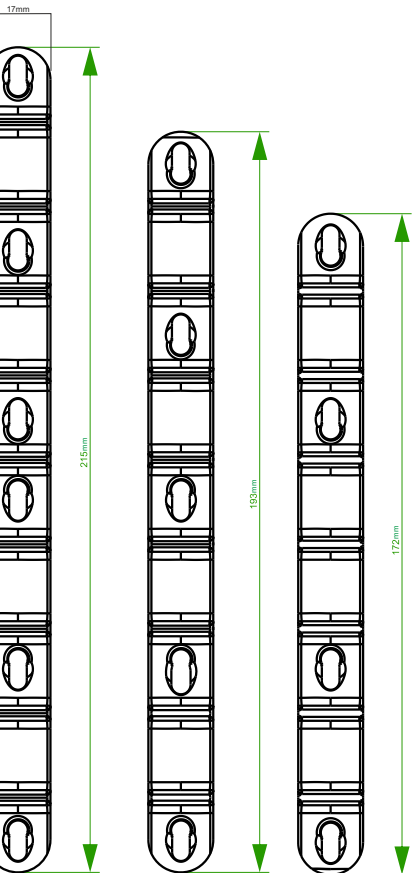

Locking screw home mechanism

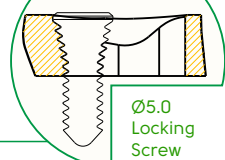

1.1.2. Cable

It is produced to assist in the fixation of other implants in bone reconstruction. It is indicated for periprosthetic fractures, trochanter reattachment, prophylactic cerclage, stabilization of bone graft material, stabilization of allograft supports, stabilization of fractures during primary and revision arthroplasty and fractures that require both coating and cerclage. There are different size Ø 2.0 mm, 500 and 700 mm in length. It is produced from Ti6Al4V Titanium, ISO 5832-1 implant steel and ASTM F 1537 CoCr in accordance with ASTM F 136 standard. Cable materials are provided non-sterile.

REF. NO (SS)	REF. NO (TI)	REF. NO (CoCrMo Alloy)	SIZE (mm)
6081-2050	6082-2050	6083-2050	2.0X500
6081-2070	6082-2070	6083-2070	2.0X700



Cable

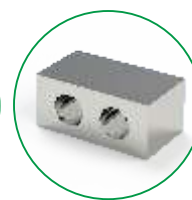

Cable Sleeve



2.1. Plate and Cable placement

Before fixing with the cable, the cable wide plate can be fixed to the appropriate area with screws of suitable length in order to prevent plate migration.(Fig.1)

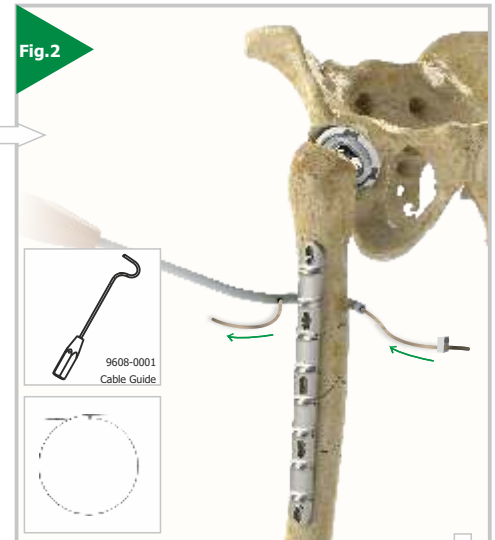

After placing the cable guide as shown in the picture, advance the cable through the channel on the guide.(Fig.2)

After adjusting the cable according to the wire line on the plate, remove the cable guide. (Fig.3)



Pass the cable through the holes on the cable sleeve.(Fig.4)

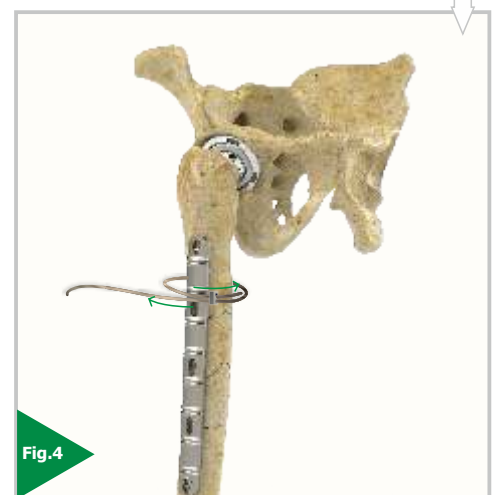



2.2. Cable Tensioning

Place the two ends of the cable properly to the cable tensioner and perform the cable tensioning. (Fig.5)

Cable Tensioner

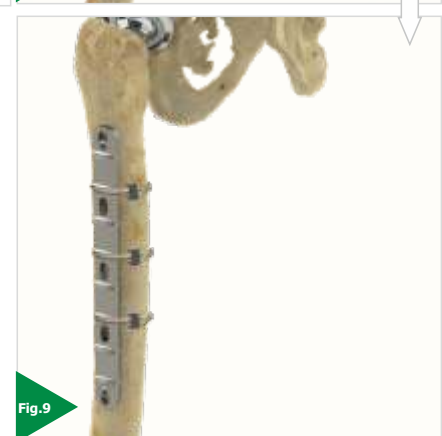
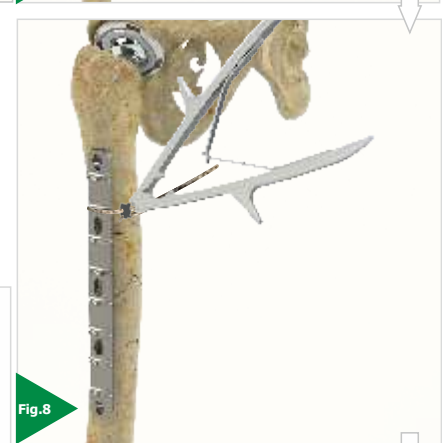
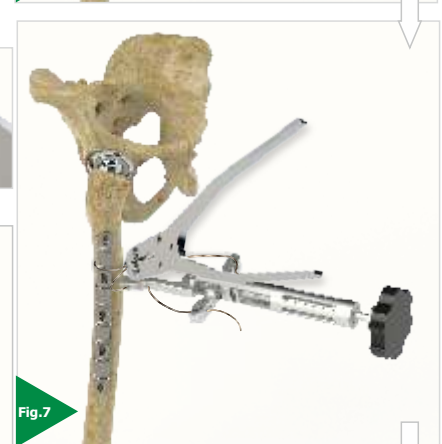
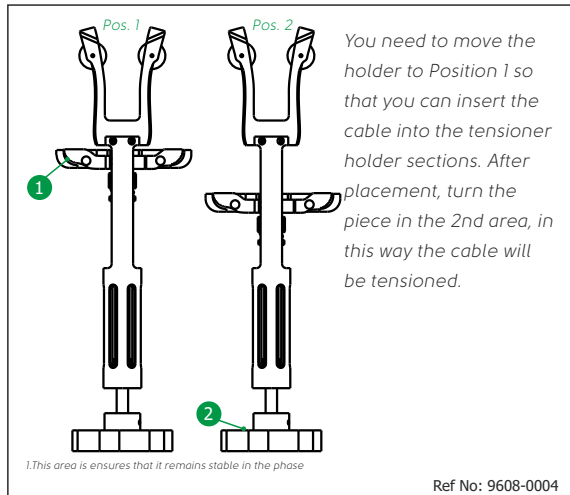

2.3. Cable Fixing

Once you have enough tension, squeeze the cable sleeve on its short sides (Fig.6) with the cable sleeve tightener (Fig.7).

2.4. Finishing

Cut the remaining cable extensions with a cable cutter. (Fig.8)

Apply the cable application procedure to other cable lines according to fracture and plate length. (Fig.9)



3.1. Instrument Set - 1.Tray

- | | | |
|---|-----------|--------------------------|
| 1 | 9608-0001 | Cable Guide (Two Pieces) |
| 2 | 9608-0002 | Cable Sleeve Compressor |
| 3 | 9608-0003 | Cable Cutter |

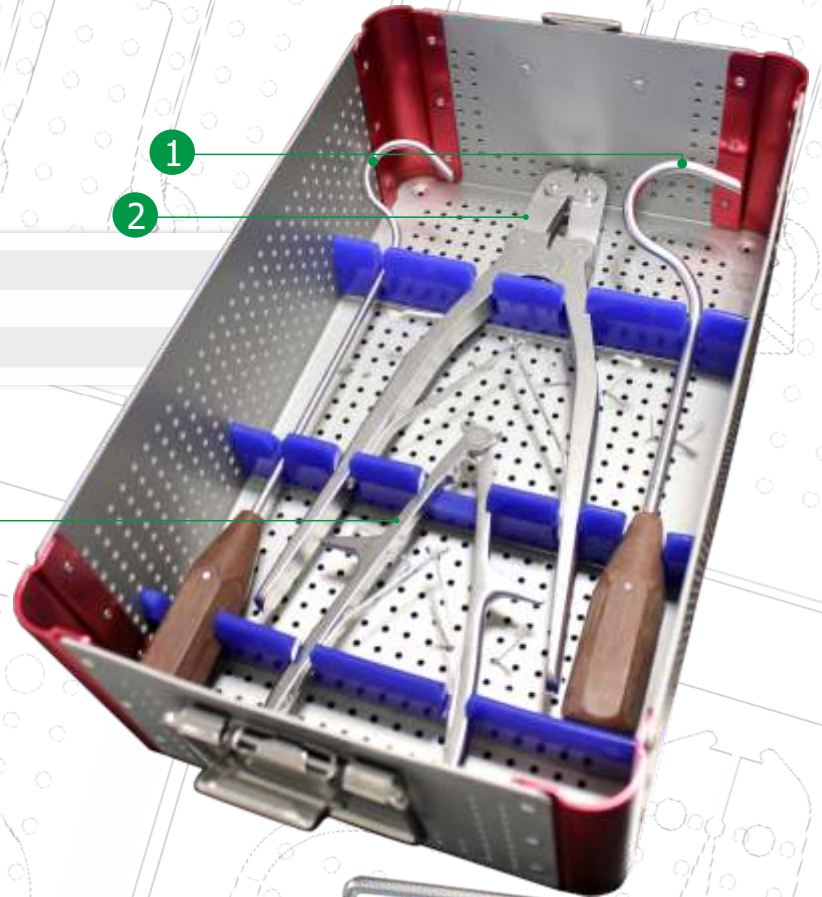

3.2. Instrument Set - 2.Tray

- | | | |
|---|-----------|-------------------------------|
| 4 | 9608-0004 | Cable Tensioners (Two pieces) |
|---|-----------|-------------------------------|

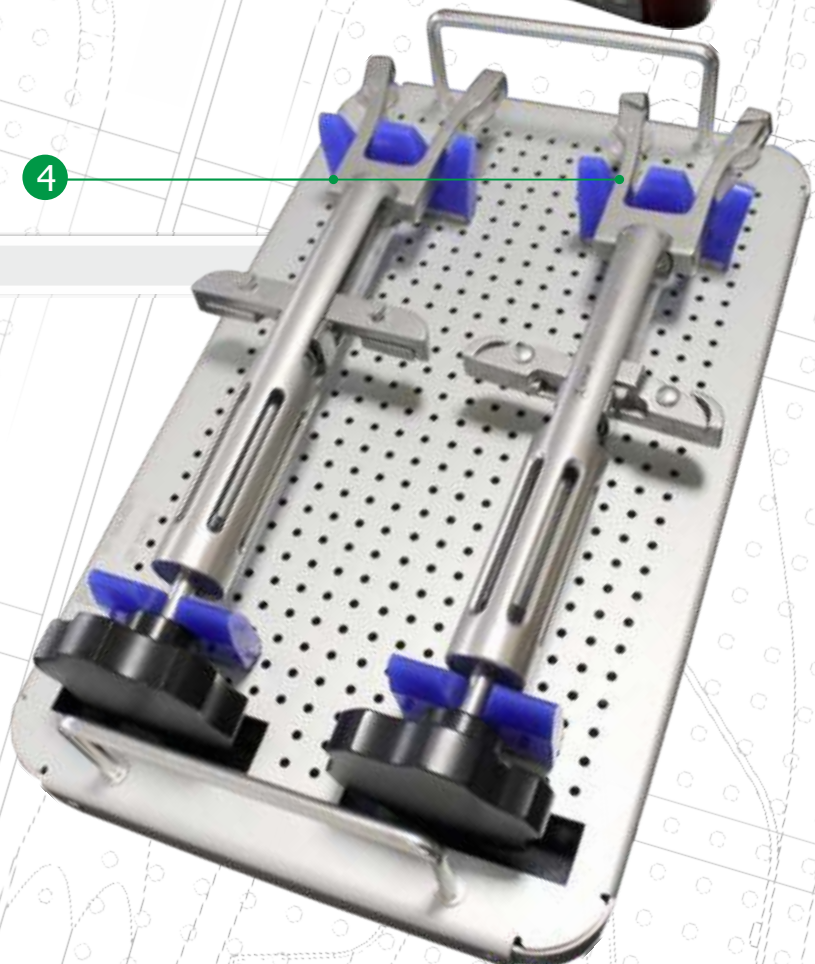



4.1. DEVICE CLEANING CONDITIONS

Do not use metal brushes or rubbing pads during Decontamination of the tools should be performed immediately after the surgical procedure is completed. Contaminated tools must not be allowed to dry before reprocessing.

Excessive blood or debris must be removed in order to prevent the drying on the surface. All users must be qualified staff with documented evidence of training and competence. Training should include the current guidelines, standards and hospital policies. Even if they are made of high-grade stainless steel, the surgical tools must be thoroughly dried in order to prevent rust formation. Prior to sterilization, all the tools should be examined for the cleanliness of the lumens of the joints of the surfaces. manual cleaning process. Use cleaning agents with low-foam surfactant to be able to see the tools in the cleaning solution. Rinse the cleaning materials easily from the tool in order to prevent residue formation.

Mineral oil or silicon lubricants should not be used on Zimed tools. Neutral pH enzymatic and cleaning materials are recommended for cleaning the reusable instruments. It is very important to neutralize and rinse the alkaline cleaning materials thoroughly from the tools. Anodized aluminum should not contact with certain cleaning or disinfectant

4.1.1. Manual Cleaning/Disinfection:

Prepare the enzymatic and cleaning materials at the dilution rates and temperatures as recommended by the manufacturer. New solutions should be prepared when the existing solutions are heavily contaminated. Place the tools in the enzymatic solution so that they are completely immersed. Operate all the movable parts so that the detergent contacts with all the surfaces.

Keep in the fluid for minimum 20 min. Use a nylon, soft-bristled brush to gently rub the tools until all visible debris is cleaned. Pay particular attention to the accessible areas and use a suitable bottle brush. In order to remove the dirt in the open springs, coils or flexible parts, wash the recesses with plenty of cleaning solution. Rub the surface with a scrubbing brush to remove all the visible dirt from the surface and the recesses. To ensure that all the recesses are cleaned, turn the component while rubbing. Remove the tools and rinse them for minimum 3 min. under running water. Pay particular attention to the cannulas and use a syringe to pass the fluid through the hard-to-reach areas. Place all the tools that are completely immersed in water, in an ultrasonic unit containing the cleaning solution. Operate all the movable parts so that the detergent contacts with all the surfaces. Expose the tools to sonification process for minimum 10 min..

Remove the tools and rinse with deionized water for at least 3 minutes or unless all the blood or dirt traces are eliminated in the rinsing water. Examine the tools under

normal light to verify that visible dirt is removed. If visible dirt is present, repeat the above mentioned sonification procedure and the rinsing steps. Remove the excessive moisture on the tool with a

4.1.2. Combination Manual / Automated Cleaning and Disinfection:

Prepare the enzymatic and cleaning materials at the dilution rates and temperatures as recommended by the manufacturer. New solutions should be prepared when the existing solutions are heavily contaminated. Place the tools in the enzymatic solution so that they are completely immersed. Operate all the movable parts so that the detergent contacts with all the surfaces. Keep in the fluid for minimum 10 min. Use a nylon, soft-bristled brush to gently rub the tools until all visible debris is cleaned. Pay particular attention to the accessible areas and use a suitable bottle brush. A sonicator will help to clean the instruments thoroughly. The use of a syringe or a water fountain will facilitate passing of the liquid from the low-spaced areas and difficult-to-access areas. Remove the tools from the enzyme solution and rinse them for minimum 1 min. under deionized water. Place the tools in a suitable washer / disinfectant basket and perform a standard washer / disinfectant cycle. Specific minimum parameters are essential for a complete cleaning and disinfection. These parameters are given in a below

4.1.3. Combination Manual / Automated Cleaning and Disinfection:

Automated washing / drying systems are not recommended as the only cleaning method for surgical tools. An automated system can be used as a follow-up operation after manual cleaning. To ensure an effective cleaning, tools must be thoroughly examined before sterilization. For detailed information on Washing and Disinfection see

Specific minimum parameters used for a complete cleaning and disinfection:

	Definition
1	Pre-washing for 2 minutes with cold tap water
2	enzyme spray for 20 seconds with hot tap water
3	Immersion in enzyme after 1 minute
4	rinsing for 15 seconds with cold tap water (Should be repeated twice)
5	Washing with detergent for 2 minutes with hot tap water
6	rinsing for 15 seconds with hot tap water
7	Rinsing with 10 seconds with optional lubricated purified water
8	Drying for 7 minutes with hot air

Note: Follow the instruction of the washer/disinfectant manufacturer

● *Zimed Medical, as the manufacturer of this device, and their surgical consultants do not recommend this or any other surgical technique for use on a specific patient. The surgeon who performs any implant procedure is responsible for determining and utilizing the appropriate techniques for implanting the device in each individual patient. Zimed and their surgical consultants are not responsible for selection of the appropriate surgical technique to be utilized for an individual patient.*

zimed[®]

ISO 9001
ISO 13485



www.zimed.com.tr

ST.01.04.02 (Rev.01) 14.10.2020